

WARNING! Buyer/user assumes all responsibility for safety and proper use not in accordance with the directions and safety labels.

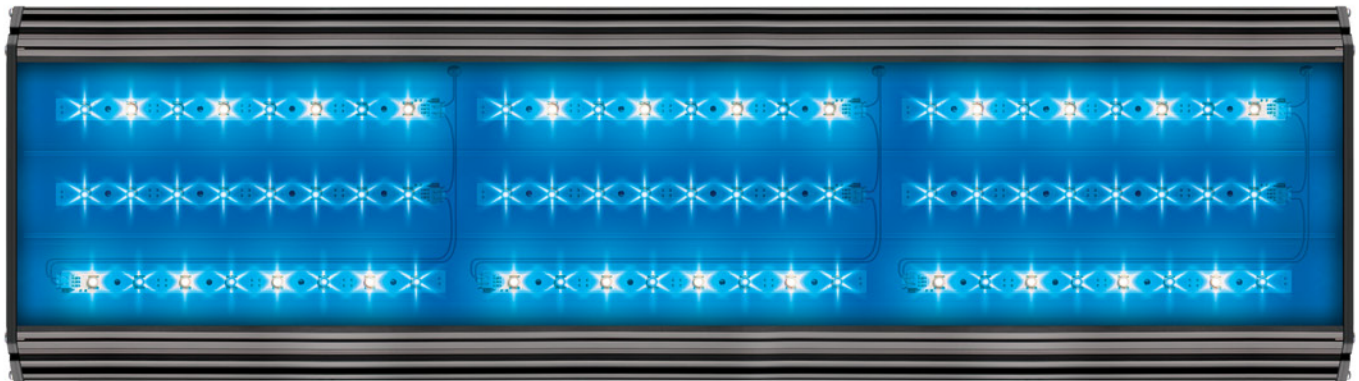
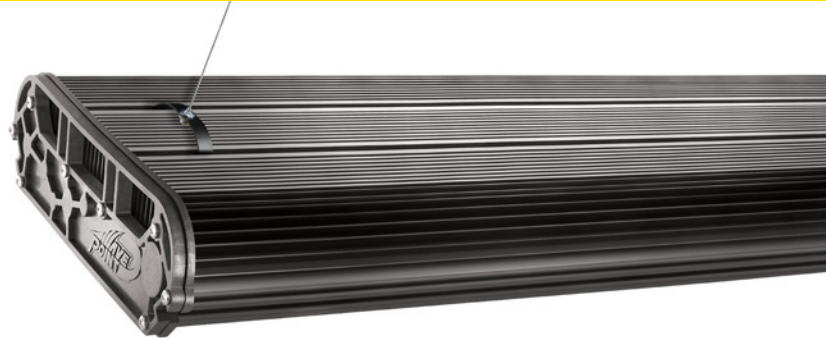

HO LED LIGHTING SYSTEM

- Premium 3.5 watt HO LED lamps
- 90° degree focused conical lens aperture
- Premium UL listed GFCI plug with 92" power cord
- HD extruded aluminum hood with Heat Removal Technology
- Ultra-silent, no fans needed
- Included: Hanging kit

- *READ AND FOLLOW THE GUIDELINES TO ENSURE THE PROPER USE AND APPLICATION. FAILURE TO FOLLOW THESE GUIDELINES MAY RESULT IN FIXTURE DAMAGE, ELECTRICAL SHOCK, FIRE AND/OR INJURY.*
- *WARNING! LAMPS CAN BE HOT. HANDLE WITH CARE.*
- *NEVER TOUCH THE LAMP WHILE OPERATING. BEFORE WORKING ON THE FIXTURE AND/OR AQUARIUM, THE FIXTURE MUST BE DISCONNECTED FROM THE POWER SUPPLY.*

PART LIST

1. HD aluminum extruded hood HTR Technology
2. 3.5 w HO LED's
3. Plastic splash guard
4. GFCI plug and power cord
5. Right side endcap
6. Left side endcap
7. Endcap

8. Wire connection e-39
9. Wire lock nut e-39
10. 16x Screw 3.5/8
11. Hanging Kits

1 HD aluminum extruded hood HTR Technology

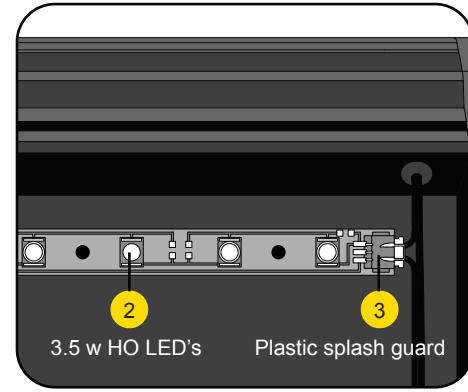

4 GFCI plug & power cord

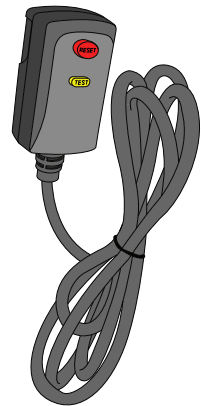

5 Right side endcap

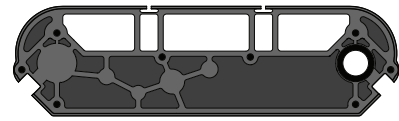

6 Left side endcap

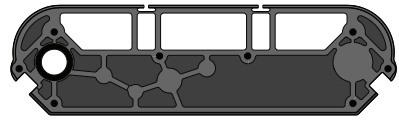

7 Endcap

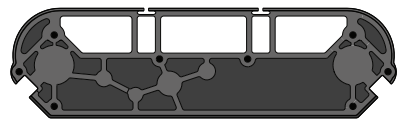

8 Wire connection e-39

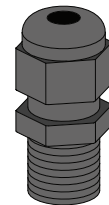

9 Wire lock nut e-39

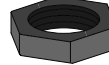

10 16x Screw 3.5/8



11 Hanging Kits

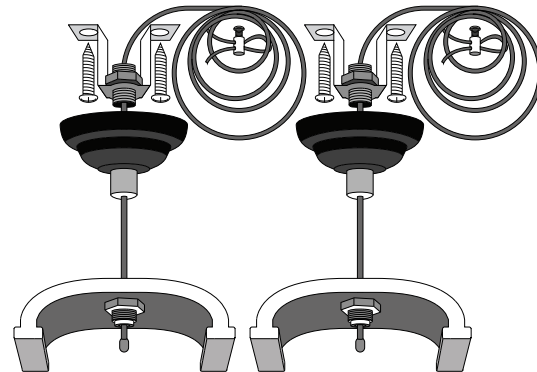

IMPORTANT WARNING AND SAFEGUARDS

This product may contain chemicals known to the state of California to cause cancer and or birth defects or other reproductive harm. Wash your hand after handling this product.

It is your sole responsibility to verify that the plug and the receptacle are clean and free of moisture and salt build up at all times. The receptacle must be free of water, salt, calcium, magnesium and dust. Failure to do so can cause fire, damage to property, permanent damage to the product and personal injury not limited to loss of life.

Do not plug into extension cord/power strip.

Hg lamp contains Mercury
Manage in accordance with disposal laws
See: www.lamprecycle.org

A drip loop must be used when plugging all electrical aquarium devices. A drip loop is that part of the cord hanging below the receptacle.

The national code requires that a GFCI (Ground fault circuit interrupter) be used in the branch circuit supplying all power to water pumps and electrical aquarium equipment. If you do not have a GFCI, have an electrician install one prior to operating any aquarium component.

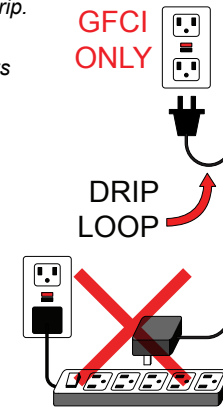

Read and follow the guidelines to ensure the proper use and application. Failure to follow these guidelines may result in light fixture damage, electrical shock, fire and/or injury.

1. Use this product for its intended use only.
2. Never yank or pull the cord from the electrical outlet.
3. Do not place the light fixture directly on top of the aquarium without using the hanging kit
4. Do not operate if the plug or wire is damaged.
5. The light fixture is not to come in contact with water.
6. The light fixture must be turned off/disconnected from the power supply before any maintenance is done to either the light fixture or the aquarium.
7. Verify that hands are dry prior to disconnecting the power.
8. To reduce the risk of electrocution keep all connections dry.
9. If the light fixture falls or comes in contact with water/excess moisture, unplug the light fixture from the power supply immediately before removing. Failure to do so may cause electrical shock or injury.
10. The light fixture and connections need to be free of water, moisture and salt build up at all times. Failure to do so will cause electrical arcing resulting in possible fire or electrical shock.
11. Do not place above an open top aquarium.

CAUTION:

When upgrading lights from an existing aquarium certain precautions need to be taken. When changing any lighting on an established aquarium there will be a variance of light intensity and or color temperature of lighting and animals will take time to adjust. It may be necessary to raise the light, reduce light cycle and even change the position of corals/animals. Always consult with your local fish store for proper procedures when changing lighting from an existing aquarium.

AVAILABLE MODEL:

BlueStar™ Daylight HO LED Lighting System with Dual AC Cords: Each foot of the light hood consists of three strips of eight 3.5 watt LED lamps. Outside strips: 4 white & 4 blue. Inside strip: 8 blue. Total of 84 watt per foot.

| MODEL # | DESCRIPTION | DIMENSION (APPROX.) |
|---------|---|-----------------------|
| 01046 | 12in 84 watt 8 white & 16 blue 3.5 watt LED lamps | 9.25 x 2.75 x 12.25in |
| 01026 | 24in 168 watt 16 white & 32 blue 3.5 watt LED lamps | 9.25 x 2.75 x 23.75in |
| 01027 | 36in 252 watt 24 white & 48 blue 3.5 watt LED lamps | 9.25 x 2.75 x 35.25in |
| 01028 | 48in 336 watt 36 white & 72 blue 3.5 watt LED lamps | 9.25 x 2.75 x 46.75in |

DayStar™ Daylight HO LED Lighting System with Single AC Cord: Each foot of the light hood consists of three strip of eight 3.5 watt LED lamps. All strips: 4 white & 4 blue. Total of 84 watt per foot.

| MODEL # | DESCRIPTION | DIMENSION (APPROX.) |
|---------|---|-----------------------|
| 01087 | 12in 84 watt, 12 white & 12 blue 3.5 watt LED lamps | 9.25 x 2.75 x 12.25in |
| 01088 | 24in 168 watt 24 white & 24 blue 3.5 watt LED lamps | 9.25 x 2.75 x 23.75in |
| 01089 | 36in 252 watt 36 white & 36 blue 3.5 watt LED lamps | 9.25 x 2.75 x 35.25in |
| 01090 | 48in 336 watt 48 white & 48 blue 3.5 watt LED lamps | 9.25 x 2.75 x 46.75in |

REPLACEMENT PART

| MODEL # | DESCRIPTION |
|---------|---|
| 01095 | Hanging Kit for HO LED lighting system |
| 01092 | Wave Point® light stand mount (optional part, not included) |

INSTRUCTIONS FOR INSTALLATION

NOTE: Only place in well ventilated canopy. This light fixture is intended to be above the aquarium. Do not place directly on top of any aquarium without using mounting legs. Do not place above the aquarium without a glass top.

INSTALLING HANGING KIT TO THE FIXTURE

Additional hardware and tools required: Anchors, drill and a screwdriver.

Approximate weight of hoods: 12in = 6lbs, 24in = 12 lbs, 36in = 16 lbs & 48in = 24 lbs

1. Unit must be disconnect from the power.
2. Undo lock nut. (B)
3. Locate a wood beam in the ceiling. Using the mounting brackets drill 2 pilot holes in the intended locations. Secure directly to the wood beam. (C)

NOTE: If using anchors to secure in the mounting brackets and wavepoint light hood. Use and follow the directions provided with the anchors for proper installation. If there are any questions or concerns consult a professional electrician or general contractor.

4. Adjust the length of the cable. Cut off or hide excess cable. Secure the end of the cable with the cable stop. (D)
5. Lock the lock nut. (E)
6. Slide mounting bracket onto the track (F). Position them equal distance from the edge. Slide bracket in a minimum of 2in from the edge of the track. (G)
7. To level the fixture adjust hanging wire to the desired height by pressing the wire outlet in and sliding cable in and out. (H)
8. Plug the unit directly to an electrical outlet. Do not use extension cords and or power strips!

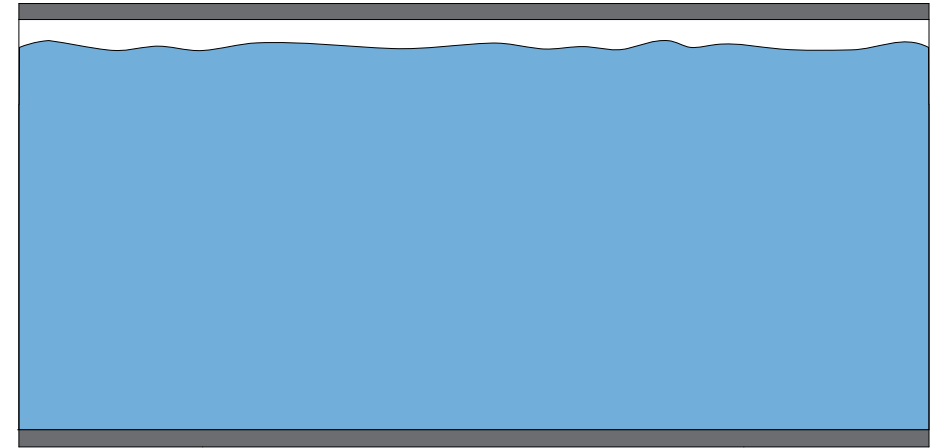
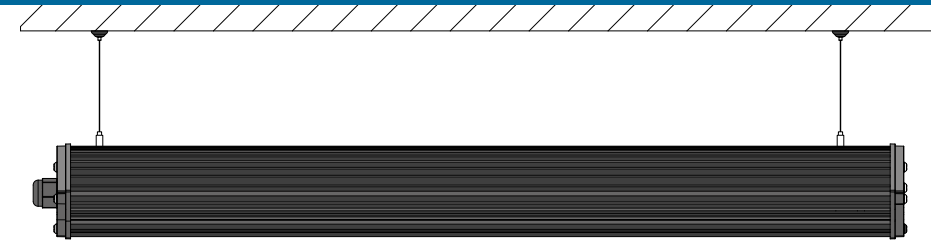
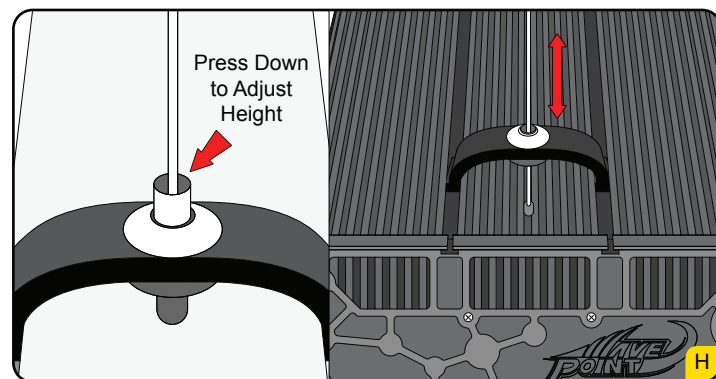
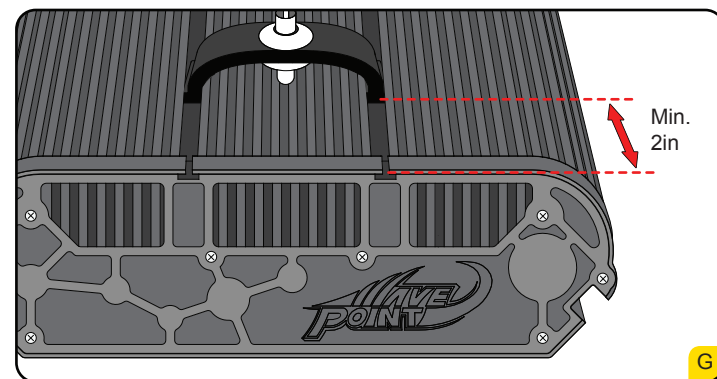
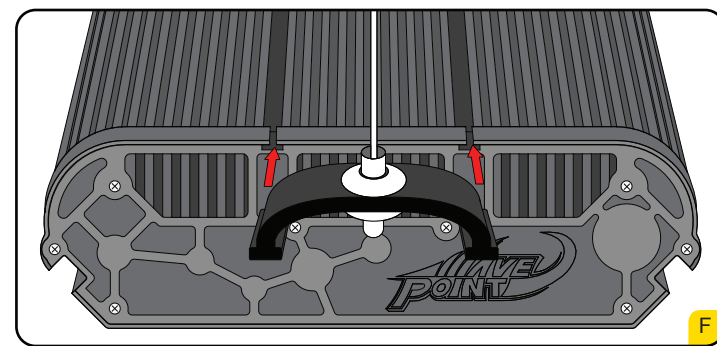
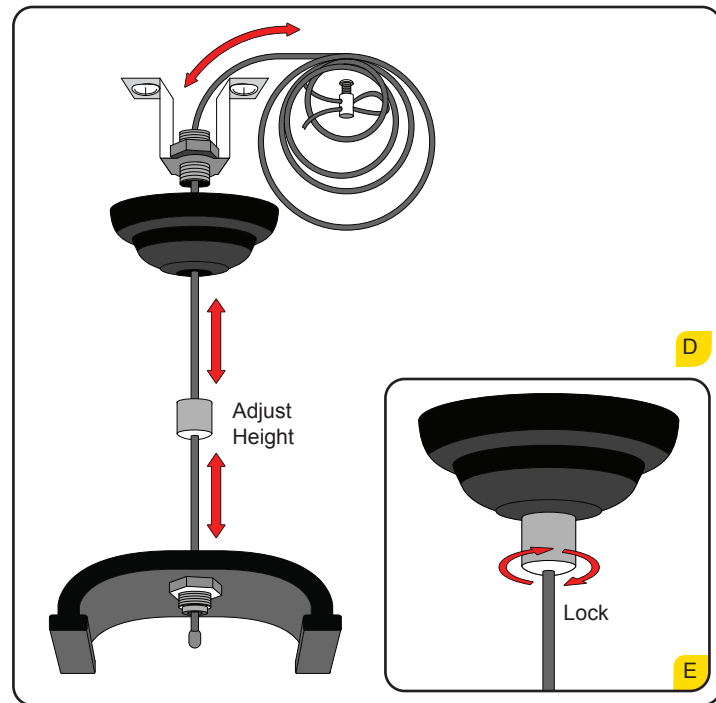
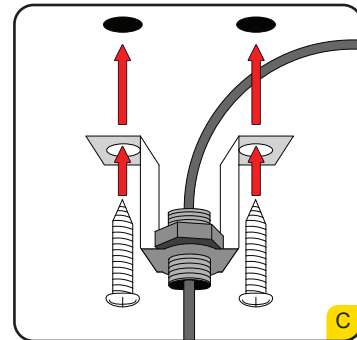
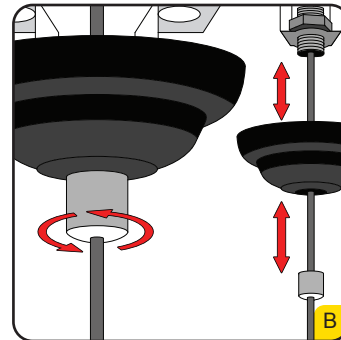
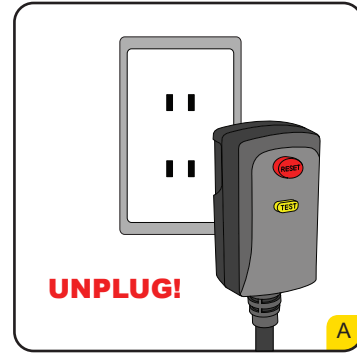

INSTALLING HANGING KIT TO LIGHT STAND MOUNT

OPTIONAL PART: Wave Point® light stand mount. Model No. 01092 (Sold separately)

Approximate weight of hoods: 12in = 6lbs, 24in = 12 lbs, 36in = 16 lbs & 48in = 24 lbs

9. Loosen the cable stop and slide off the mounting bracket
10. Cut wire to the desired length
11. Slide wire through the stand pipe (I)
12. Secure with cable stop (J)
13. Repeat step 6 to 8 from page 4

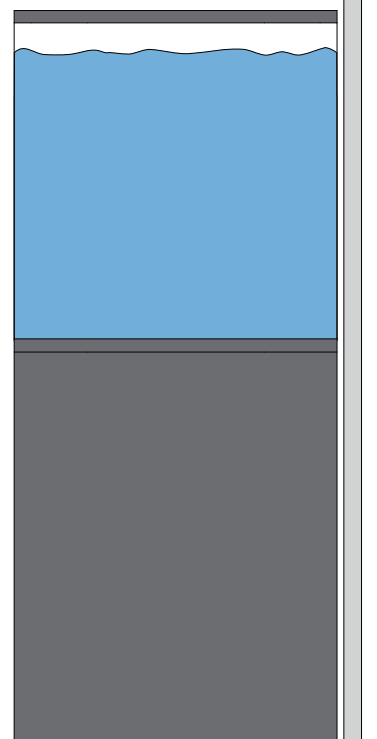
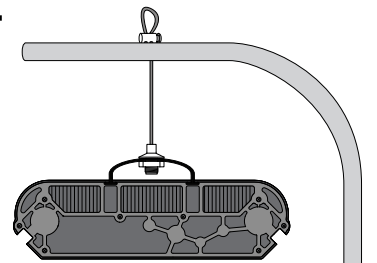
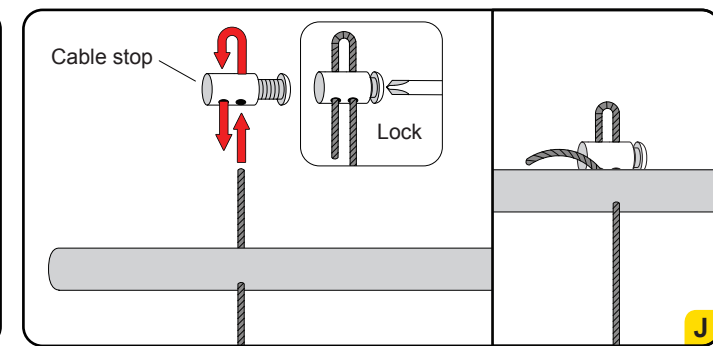
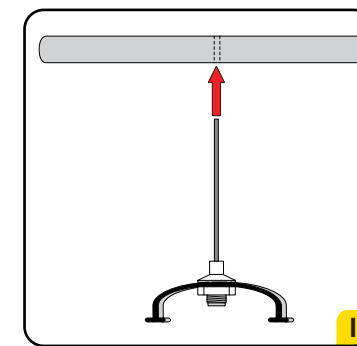

TROUBLESHOOTING

IF YOU HAVE ANY PROBLEMS VISIT OUR WEBSITE
WWW.WAVE-POINT.COM

OR CALL 805.383.3566 EXT 102

CHECK OUR WEBSITE FOR UPDATED INFORMATION ON REPAIR OR REPLACEMENT OF THE LED STRIPS AND DRIVERS.

30 DAY PRODUCT GUARANTEE

- **If within 30 days of purchase** you experience any problems with this Wave Point® Technology product, **return it to the retailer** where purchased for replacement. Product must be returned in its original box, with all original parts and must be accompanied by the original receipt as proof of purchase.
- **Products beyond the 30 days of purchase** that experience problems **should NOT be returned to the retailer, supplier, or distributor**. These Wave Point® products fall under the auspices of the Wave Point® Technology 1 year limited direct manufacturer warranty. All such problems must be addressed directly with Wave Point® by the warranty holder (see below).

1 YEAR DIRECT MANUFACTURER LIMITED WARRANTY

- WavePoint® Technology Inc. products are warranted to all registered warranty product owners to be free of defect in materials and workmanship for one (1) year from date of purchase.
- **URGENT: Fill out the warranty registration card included in this box** to activate registration in the Wave Point® limited warranty program. Warranty card must be completed and returned to Wave Point® Technology **within thirty (30) days of purchase** (Warranty Card).
- Under this program, Wave Point® Technology will, at its election, repair, replace or make appropriate adjustment where inspection by the Wave Point® company discloses any such defects occurring in normal usage within one (1) year after consumer purchase.
- Only properly registered products are eligible for this warranty service.
- After the 30 (thirty) day guarantee has expired, contact Wave Point® Technology directly for warranty product repair. Do NOT return such Wave Point® products to the retailer, distributor or supplier for repair or replacement.
- Wave Point® Technology is not responsible for any removal, installation or shipping costs incurred in the warranty process.
- Lamps are not covered under the 1 Year limited warranty.
- Warranty is void if the failure of Wave Point® product or system or any part, sealant or component thereof is found to be caused by misuse, tampering, negligence, abuse, misapplication, failure to properly maintain the product, failure to keep dry (not to come in contact with water), salt build up, or use without Ground Fault Circuit Interrupter.
- This warranty is non-transferable.
- This warranty is limited to possible parts replacement and labor connected therewith. Wave Point® Technology is not liable for any incidental or consequential damages including but not limited to loss of life, personal injury, property damage, damage to equipment, or lost wages, income, profits or savings.

Note: some US states do not allow liability limitations or exclusions on incidental or consequential damages to the extent listed in the above disclaimer. Check your local state regulations for details on regulations specific to your state.

NOTE: WAVE POINT® TECHNOLOGY'S WARRANTY POLICY IS SUBJECT TO CHANGE WITHOUT NOTICE.

OPTIONAL 3 YEAR PREMIUM EXTENDED WARRANTY

is available for purchase online at www.wave-point.com/extendedwarranty.html

- Wave Point® Technology product owners may purchase our 3 Year Premium Extended Warranty online on our web site within 30 days of purchase prior to the expiration of the 30 Day Product Guarantee. This warranty covers all major parts and labor for 3 years from date of purchase.
- Costs are based on the equipment being placed under extended warranty. The costs for all extended warranty plans are available online on the web site.
- Lamps are not covered under 3 year extended warranty.
- For complete details and enrollment go to www.wave-point.com/extendedwarranty.html

NOTE: WAVE POINT® TECHNOLOGY'S WARRANTY POLICY IS SUBJECT TO CHANGE WITHOUT NOTICE.

RETURNING PRODUCTS FOR WARRANTY REPAIR

Contact Wave Point® Customer Support at www.wave-point.com/helpdesk.html for all trouble shooting, warranty verification and return authorization numbers.

NOTE: Products returned without Return Authorization Numbers will be refused.

Procedures:

I HAVE A COPY OF MY ORIGINAL COMPLETED WARRANTY CARD:

Wave Point® product owners seeking warranty resolution should return their Wave Point® product directly to the manufacturer along with:

1. Return Authorization Number clearly written on outside of box
2. Copy of warranty card with attached copy of original receipt as proof of purchase
3. Warranty holder's address, phone number and email address if different than listed on warranty card
4. Written explanation of problem

I DO NOT HAVE A COPY OF MY ORIGINAL COMPLETED WARRANTY CARD:

In the event you do NOT have a copy of your original completed Warranty Card you may choose instead to forward your full customer contact information and proof of purchase as listed below:

1. Return Authorization Number clearly written on outside of box
2. Copy of original receipt as proof of purchase
3. Warranty holder's name, address, phone number and email address
4. The Wave Point® serial number as listed on the product being returned
5. Written explanation of the problem

SEND TO: Wave Point® Technology *Email us at info@wave-point.com for the updated address.

Warranty Repair Desk

1011 Avenida Acaso Ste. A, Camarillo, CA 93012, USA

In the event Wave Point® products are returned for warranty work and are found to be outside the parameters of the warranty or otherwise caused by other than normal usage, the warranty holder will be contacted by phone or email and offered the option of (a) repair and return at the owner's expense, (b) return of the product to the owner "as is" at the owner's expense, or (c) disposal of the product.

Only prepaid freight returns will be accepted. All freight is the responsibility of the warranty holder.

NOTE: WAVE POINT® TECHNOLOGY'S WARRANTY POLICY IS SUBJECT TO CHANGE WITHOUT NOTICE.

RETURNING PRODUCTS FOR OUT-OF-WARRANTY REPAIR

Wave Point® owners experiencing problems with a Wave Point® product no longer under warranty may send their Wave Point® product to Wave Point® Technology for repair.

For help with, or repair of, products no longer under warranty, contact Wave Point® Customer Support at www.wave-point.com/helpdesk.html for trouble shooting tips and/or return authorization numbers. Products returned without a return authorization number will be refused.

Procedures: Wave Point® product owners seeking product repair should return their Wave Point® product directly to the manufacturer along with:

1. Return Authorization Number clearly written on outside of box
2. Owner's name, address, phone number and email address
3. The Wave Point® serial number as listed on the product being returned
4. Written explanation of problem

SEND TO: Wave Point® Technology *Email us at info@wave-point.com for the updated address.

Repair Desk

1011 Avenida Acaso Ste. A, Camarillo, CA 93012, USA

All repair and shipping costs are the responsibility of the owner. Depending on the problem and/or cost, products are not always repairable. In such instances all shipping costs remain the responsibility of the owner.

If a Wave Point® product returned for repair is found to be either non-repairable or beyond a reasonable cost to repair, the owner will be contacted by Wave Point® and offered the option of either disposal of the product or return to the owner at the owner's expense.

1 YEAR LIMITED WARRANTY OWNER REGISTRATION CARD

HO LED LIGHTING SYSTEM

- Wave Point® product owners **MUST** register their purchase with Wave Point® Technology Inc. for their warranty benefits to be in effect. **Unregistered products are not eligible for warranty.**
- This warranty card must be completed and submitted within 30 days of product purchase.
- Send this completed form along with a copy of the original retail receipt as proof of purchase to:

Wave Point® Technology *Email us at info@wave-point.com for the updated address.
Warranty Submissions Desk
1011 Avenida Acaso Ste. A, Camarillo, CA 93012, USA

OWNER INFORMATION

Date _____

Name: _____

Address: _____

City: _____

State/Province: _____

Postal Code: _____

Country _____

Email: _____

Cell Phone: _____

Work Phone: _____

Home Phone: _____

PRODUCT INFORMATION

Product Serial Number: _____

Model No. _____

(NOTE: This is the digit number located on the PIN tag affixed to the unit)

Date of Purchase: _____

Seller (Retail Outlet): _____

Seller's Location: _____

Seller's Phone Number: _____

***Affix a copy of your original purchase receipt here**

IMPORTANT: Please make a copy of this warranty card and retain it for your records.

Wave Point® Technology

www.wave-point.com

©2012 Wave Point® Technology. Photo: ©Wave Point®

Made in China. All rights reserved

SPECIFICATIONS ARE SUBJECT TO CHANGE WITHOUT NOTICE

